

PRE-TREATMENT SYSTEM - 160,000 GPD



1709 W. BALTIC PL.
ENGLEWOOD CO, 80110
PHONE: 303-985-0885

DESCRIPTION
TITLE SHEET

DWG NO.
492-CD-001

DATE:

PROJECT NO:

DRAWN BY:

CHECKED BY:

CHECKED DATE:

SCALE:

SIZE: D

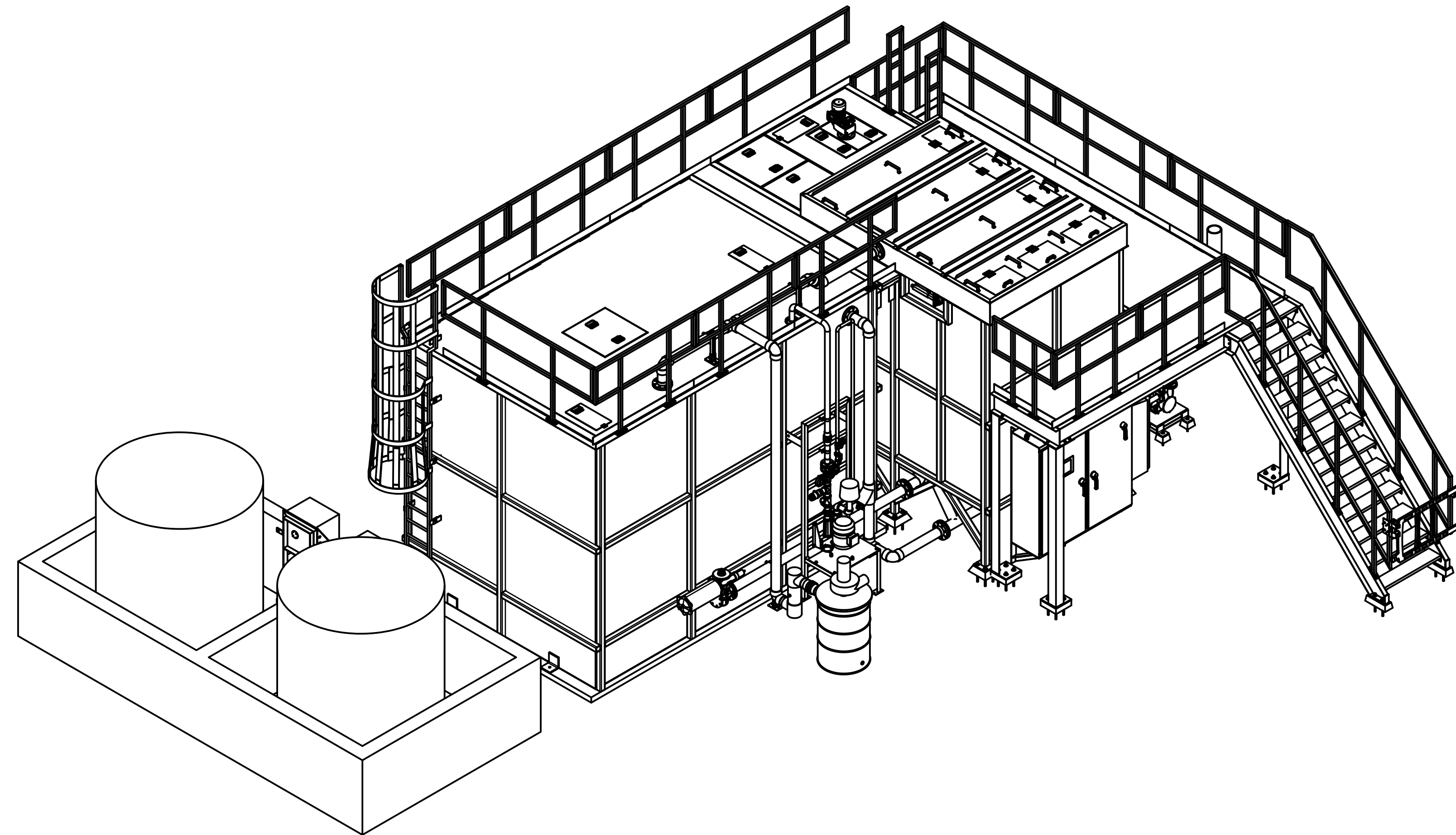

| DRAWING INDEX | | |
|---------------|-------|-------------------------|
| NO. | SHEET | DESCRIPTION |
| 1 | T-CD1 | TITLE SHEET |
| 2 | CD-2 | FRONT VIEW |
| 3 | CD-3 | PLAN VIEW |
| 4 | CD-4 | LEFT & RIGHT SIDE VIEWS |
| 5 | CD-5 | BACK VIEW |
| 6 | CD-6 | SECTION VIEW |
| 7 | CD-7 | SECTION VIEW |

| REVISIONS | | DATE |
|-----------|-------------|------|
| NO. | DESCRIPTION | |
| 1 | | |
| 2 | | |
| 3 | | |
| 4 | | |

| | |
|--|-------------------|
| <input type="checkbox"/> APPROVED AS DRAWN | SIGNATURE: _____ |
| <input type="checkbox"/> APPROVED WITH COMMENTS, NO RESUBMITTAL REQD. | PRINT NAME: _____ |
| <input type="checkbox"/> NOT APPROVED, RESUBMITTAL REQD. | DATE: _____ |

| | |
|----------------|------------------|
| SHEET T-CD1 | SHEET NO. 1 OF 7 |
|----------------|------------------|

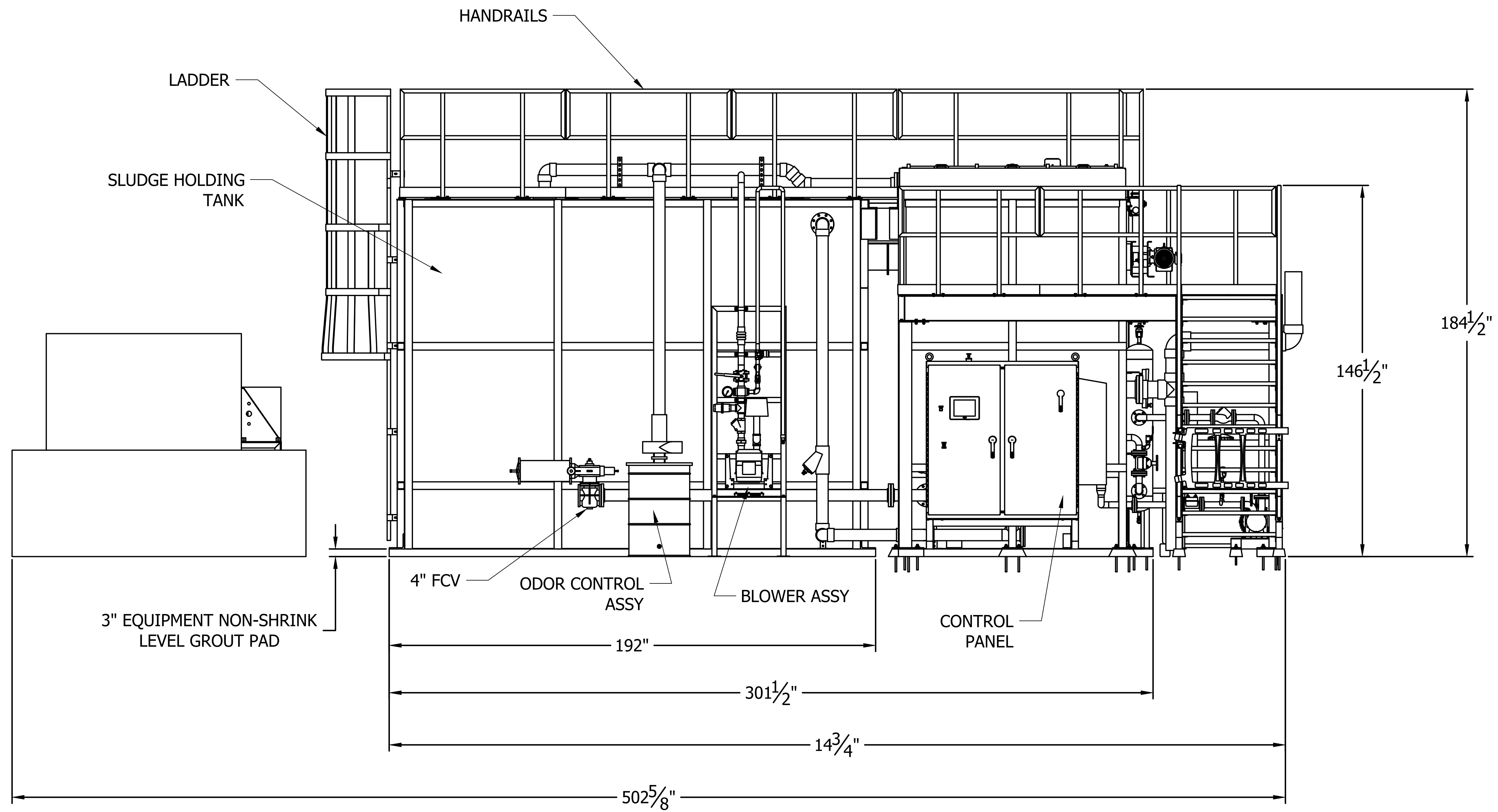

1 FRONT VIEW
Scale: 1/2" = 1'-0"

DESCRIPTION: FRONT VIEW
 DWG NO.: 492-CD-002
 DATE: _____
 PROJECT NO: _____
 DRAWN BY: _____
 CHECKED BY: _____
 CHECKED DATE: _____
 SCALE: _____
 SIZE: D

| REVISIONS | | |
|-----------|-------------|------|
| NO. | DESCRIPTION | DATE |
| 1 | | |
| 2 | | |
| 3 | | |
| 4 | | |

SHEET
 CD-2
 SHEET NO. 2 OF 7

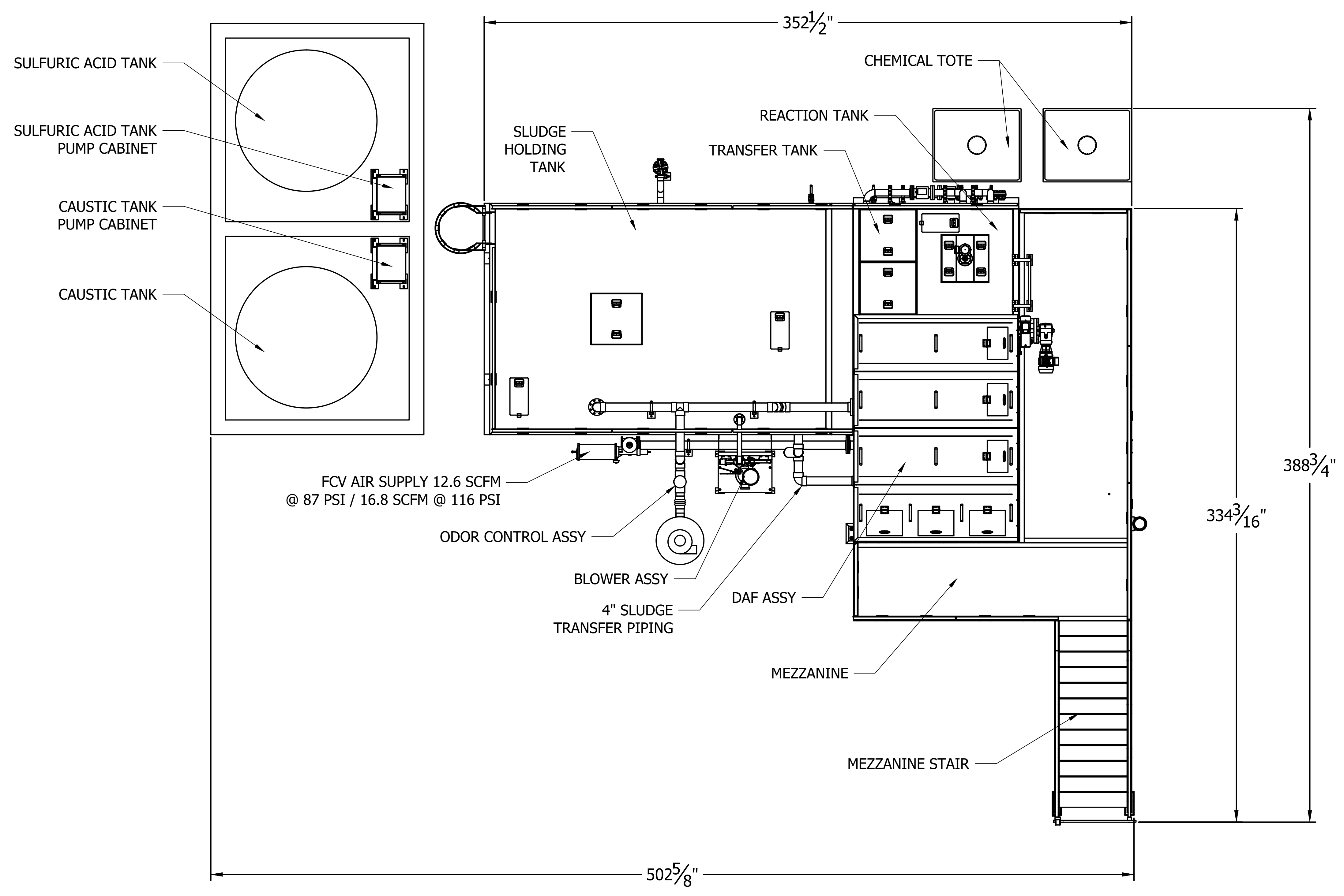

2 PLAN VIEW
Scale: 3/8" = 1'-0"

WSI
International

1709 W. BALTIC PL
ENGLEWOOD CO, 80110
PHONE: 303-985-0885

DATE: _____
PROJECT NO: _____
PROJECT NAME: _____
DRAWN BY: _____
CHECKED BY: _____
CHECKED DATE: _____
SCALE: _____
SIZE: D

DESCRIPTION
PLAN VIEW

DWG NO. 492-CD-003

| REVISIONS | | |
|-----------|-------------|------|
| NO. | DESCRIPTION | DATE |
| 1 | | |
| 2 | | |
| 3 | | |
| 4 | | |

SHEET
CD-3

SHEET NO. 3 OF 7

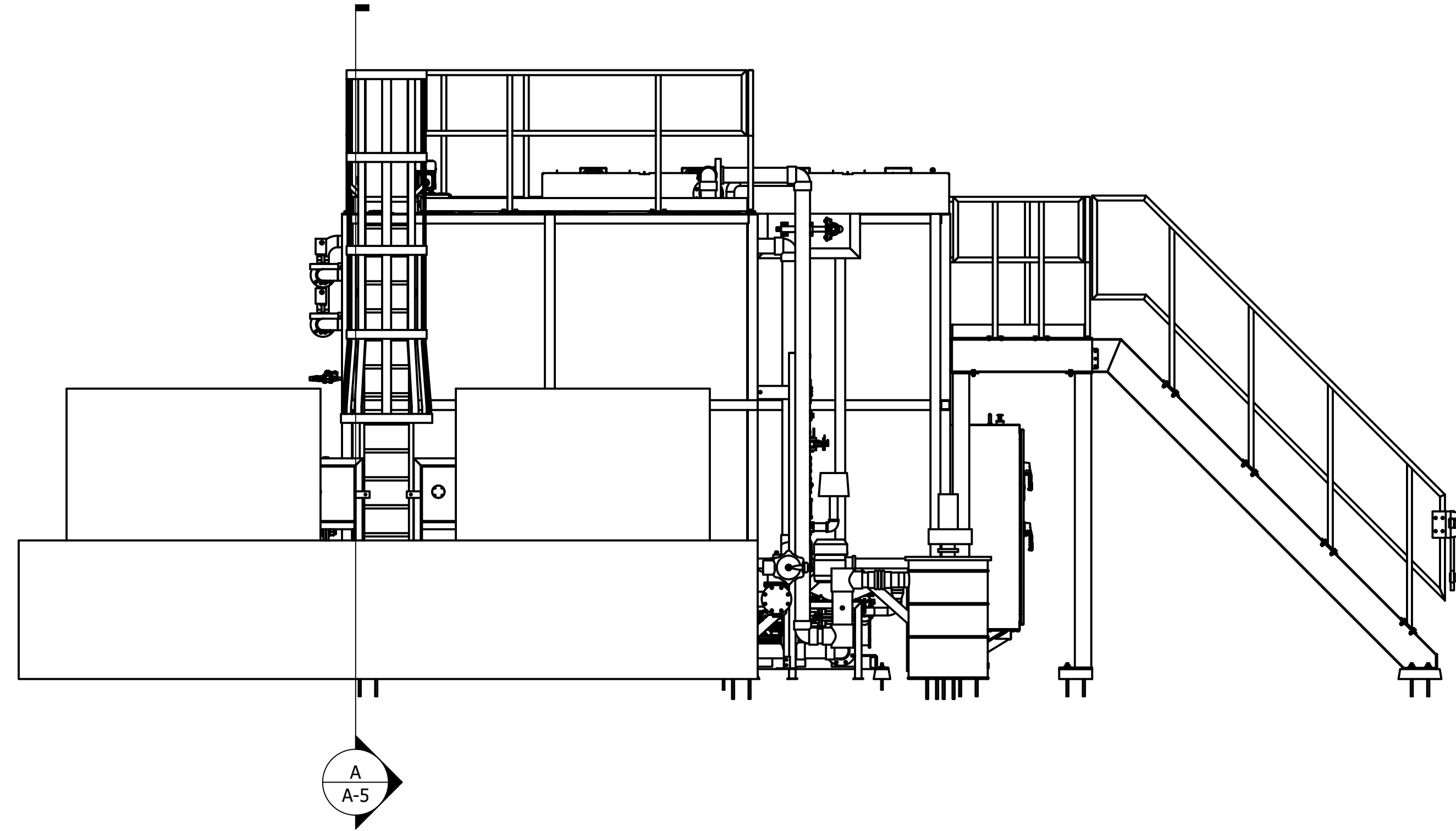

3 LEFT VIEW
Scale: 3/8" = 1'-0"

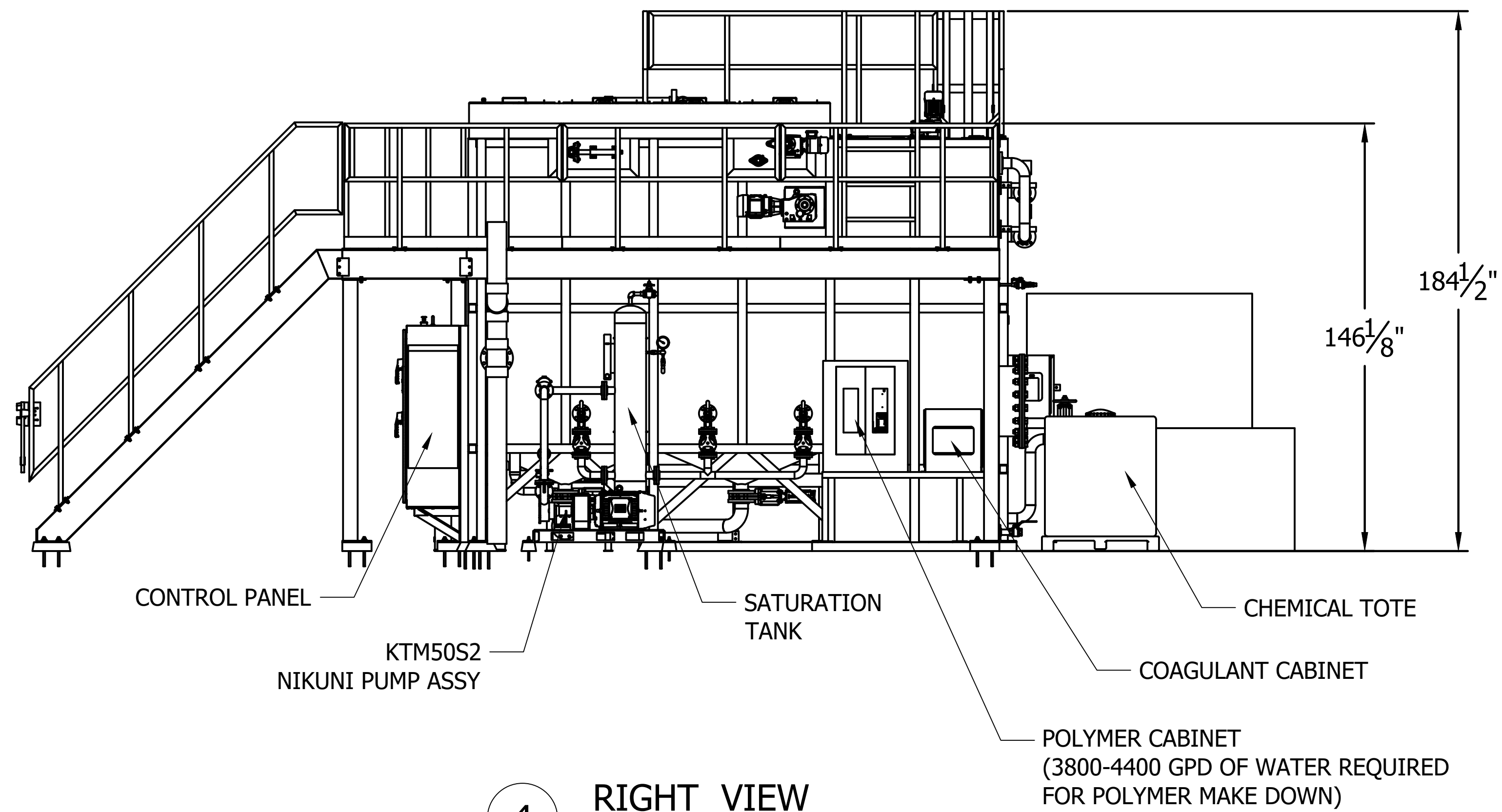

4 RIGHT VIEW
Scale: 3/8" = 1'-0"



1709 W. BALTIC PL
ENGLEWOOD CO, 80110
PHONE: 303-985-0885

DESCRIPTION
LEFT & RIGHT SIDE VIEWS

DATE:

PROJECT NO:

DRAWN BY:

CHECKED BY:

CHECKED DATE:

SCALE:

SIZE: D

DWG NO.
492-CD-004

| REVISIONS | | DATE |
|-----------|-------------|------|
| NO. | DESCRIPTION | |
| 1 | | |
| 2 | | |
| 3 | | |
| 4 | | |

| | |
|---------------|------------------|
| SHEET CD-4 | SHEET NO. 4 OF 7 |
|---------------|------------------|



1709 W. BALTIC PL
 ENGLEWOOD CO, 80110
 PHONE: 303-985-0885

DESCRIPTION
 BACK VIEW

DWG NO.
 492-CD-005

DATE:
 PROJECT NO:
 PROJECT NAME:
 DRAWN BY:
 CHECKED BY:
 CHECKED DATE:
 SCALE:
 SIZE: D

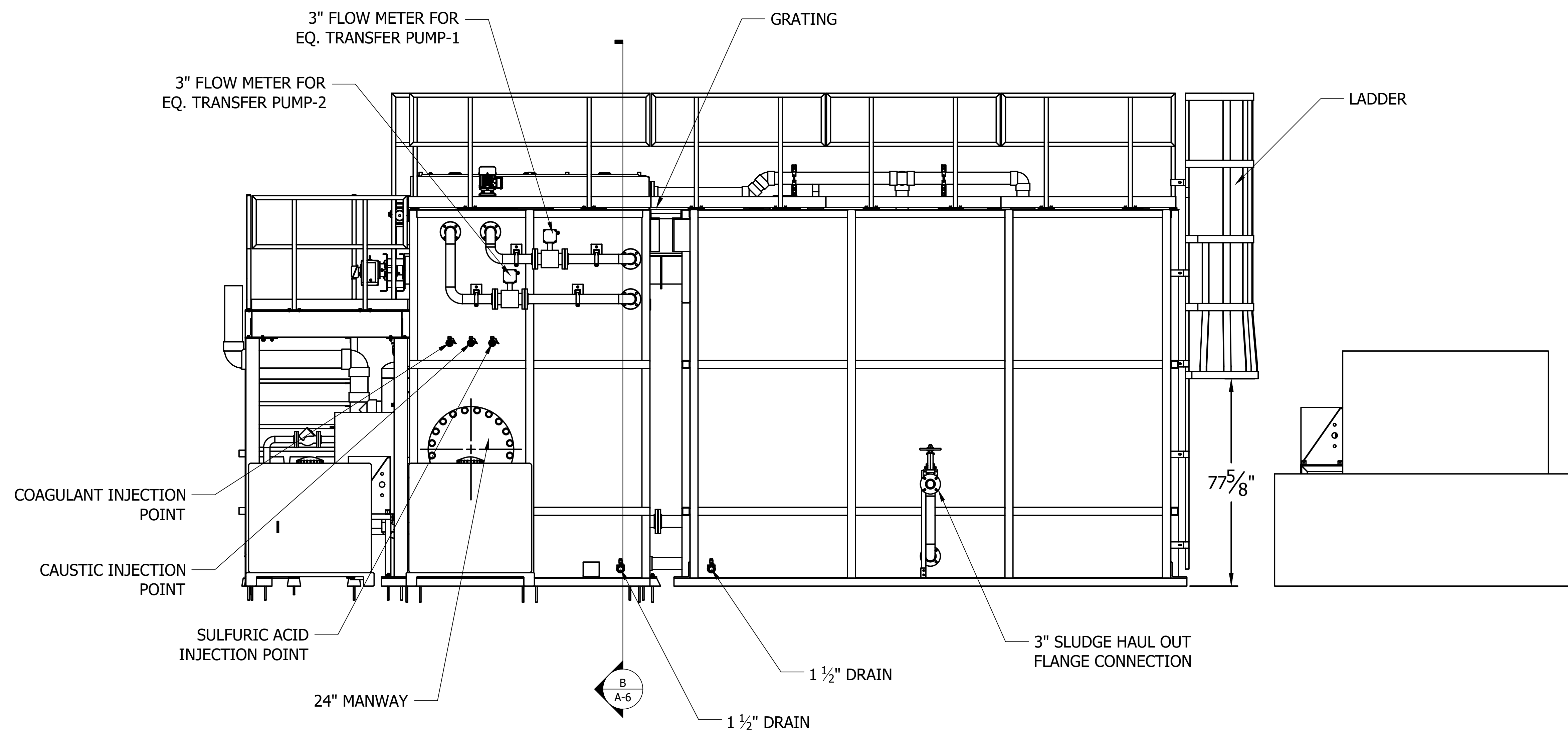

5 BACK VIEW
 Scale: 1/2" = 1'-0"

| REVISIONS | | DATE |
|-----------|-------------|------|
| NO. | DESCRIPTION | |
| 1 | | |
| 2 | | |
| 3 | | |
| 4 | | |

| | |
|---------------|------------------|
| SHEET CD-5 | SHEET NO. 5 OF 7 |
|---------------|------------------|



1709 W. BALTIC PL
 ENGLEWOOD CO, 80110
 PHONE: 303-985-0885

DESCRIPTION
 SECTION VIEW

DATE:
 PROJECT NO:
 PROJECT NAME:
 DRAWN BY:
 CHECKED BY:
 CHECKED DATE:
 SCALE:
 SIZE: D

DWG NO.
 492-CD-006

| REVISIONS | | DATE |
|-----------|-------------|------|
| NO. | DESCRIPTION | |
| 1 | | |
| 2 | | |
| 3 | | |
| 4 | | |

| | |
|---------------|------------------|
| SHEET CD-6 | SHEET NO. 6 OF 7 |
|---------------|------------------|

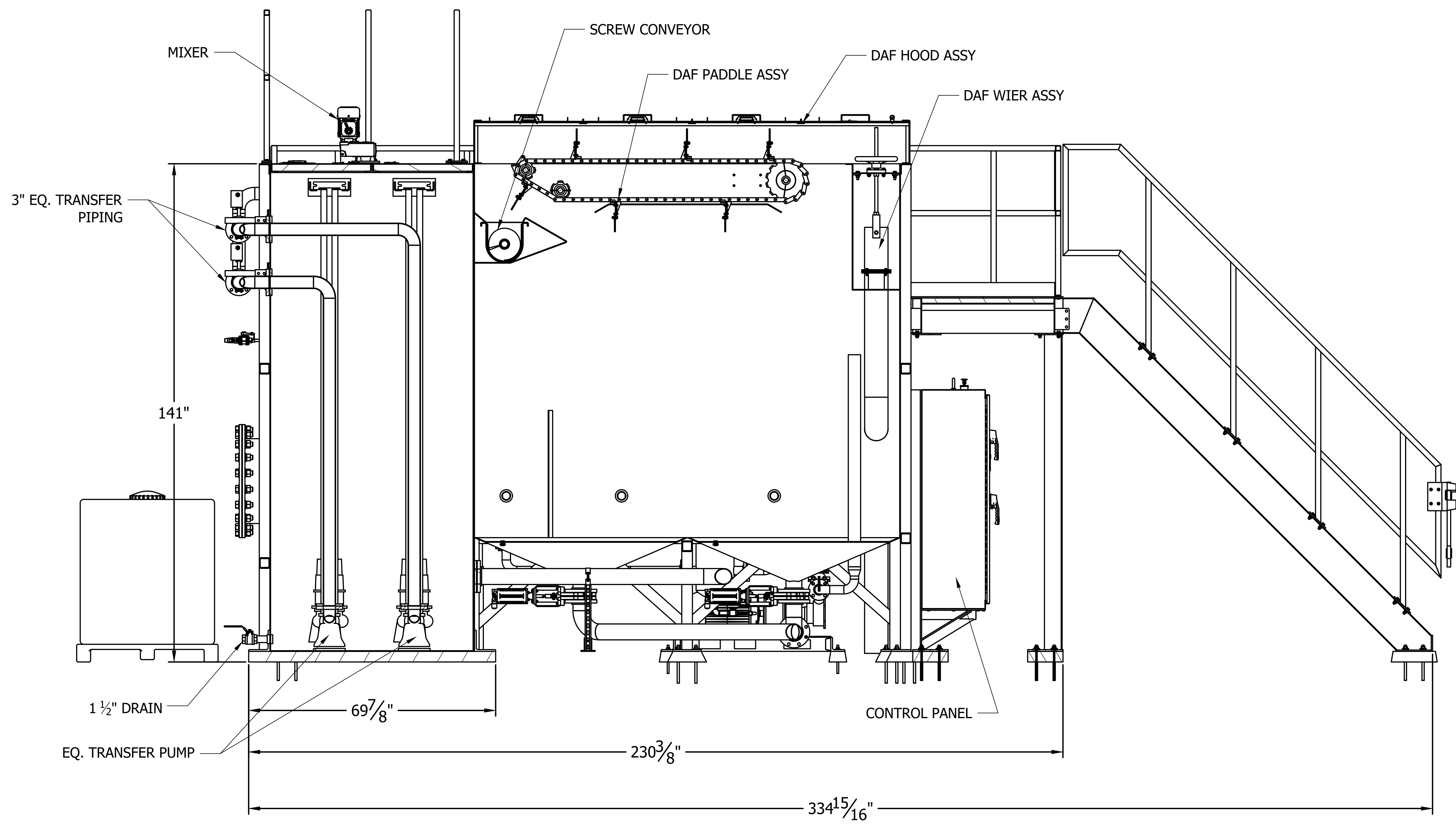

6 SECTION A-A
 Scale: 3/4" = 1'-0"



1709 W. BALTIC PL
 ENGLEWOOD CO, 80110
 PHONE: 303-985-0885

DESCRIPTION
 SECTION VIEW

DWG NO.
 492-CD-007

DATE:
 PROJECT NO:
 PROJECT NAME:
 DRAWN BY:
 CHECKED BY:
 CHECKED DATE:
 SCALE:
 SIZE: D

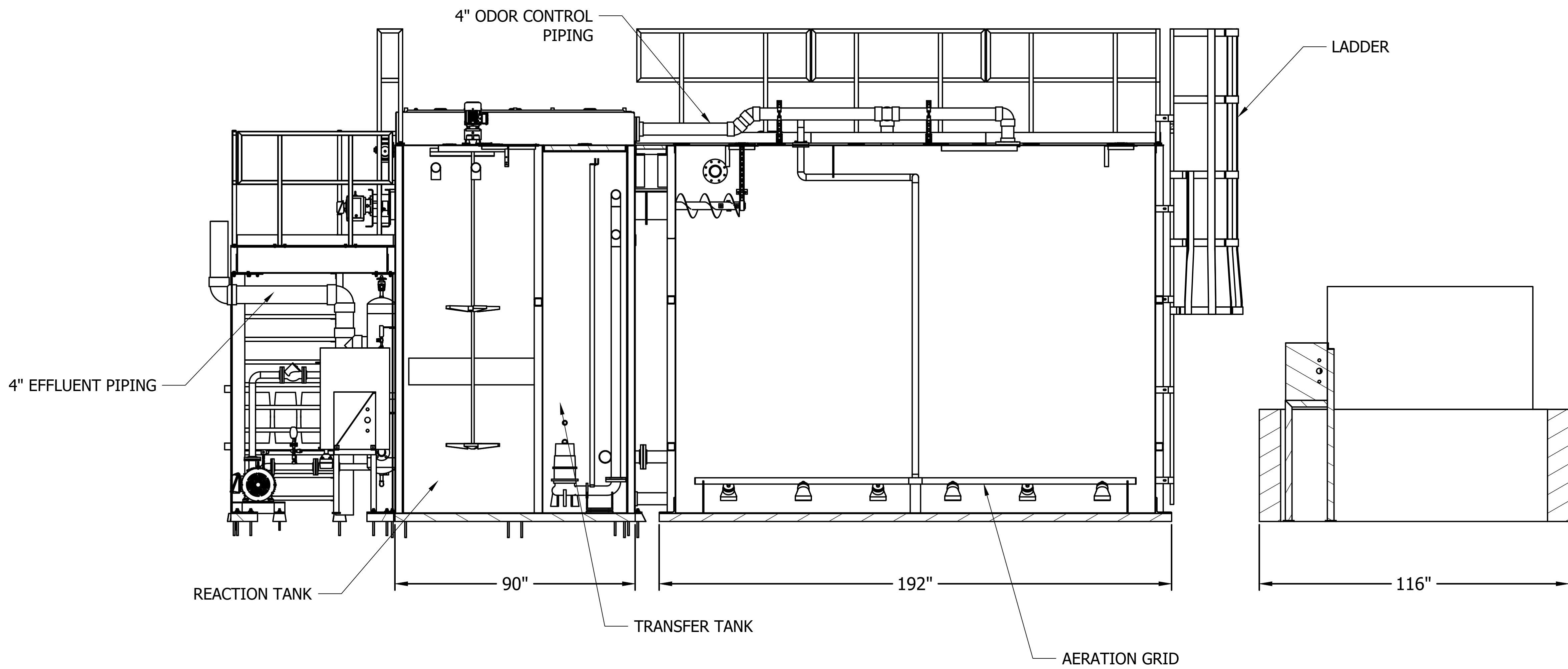

7 SECTION B-B
 Scale: 1/2" = 1'-0"

| REVISIONS | | DATE |
|-----------|-------------|------|
| NO. | DESCRIPTION | |
| 1 | | |
| 2 | | |
| 3 | | |
| 4 | | |

| | |
|---------------|------------------|
| SHEET CD-7 | SHEET NO. 7 OF 7 |
|---------------|------------------|